

E MOUNT SERIES (E21/E22)

Low-profile, all-attitude isolators for vibration and shock protection.

APPLICATIONS

- Equipment in commercial or military jet aircraft
- Missile electronics
- Ruggedized disk drives
- Random vibration environments

FEATURES

- Lightweight, low-profile, all-attitude isolators
- Available as standard plate type (E21) or optional cup type (E22)
- Axial to radial stiffness of 1:1
- Sturdy, reliable construction

BENEFITS

- Fail-safe
- Survives a 30g, 11 millisecond 1/2 sine shock input at rated load

LOAD RANGE

- 3 load ratings to 10 lbs. per mount



Barry E Series Mounts are designed for optimum shock and vibration isolation of lightweight electronic equipment, where space is a concern. E-Mounts are ideal for isolation where random vibration environments occur, such as in military or commercial aircraft applications.

Specifications

• Natural Frequency	25-40 Hertz
• Transmissibility at resonance	4.0 Max.
• Resilient Element	Hi-Damp Silicone
• Standard Materials	Aluminum w/zinc plated core
• Weight	E21 = .023 lbs. E22 = .045 lbs.

Environmental Data

- Hi-Damp Silicone operating temperature range is -67°F to +300°F (-55°C to +150°C) and storage temperature range is -100°F to +300°F (-75°C to +150°C). Elastomer is fungus and ozone resistant and meets environmental requirements of MIL-E-5400.

E MOUNT SERIES: E21

Dimensions & Performance Characteristics

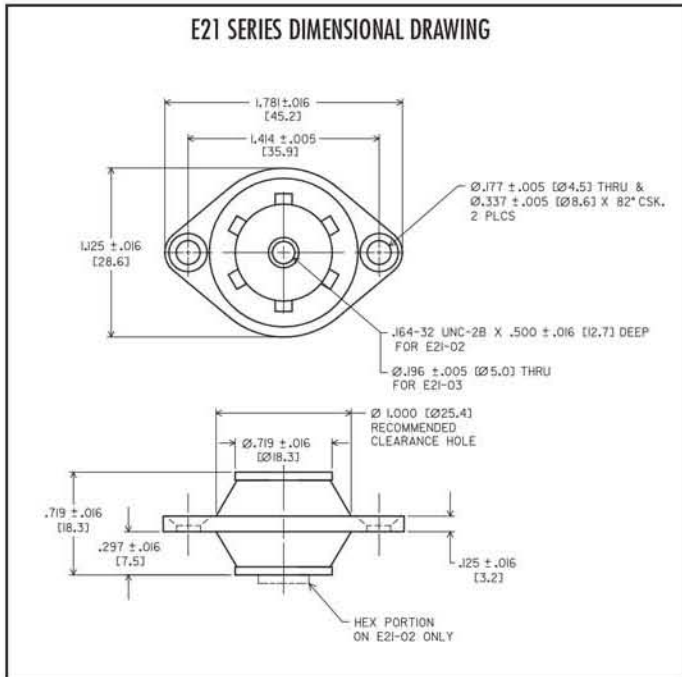

LOAD RATINGS			
Max. Load/Mount (lbs.)	Plate Type Tapped Core	Plate Type Thru Core	Weight (lbs.)
4.50	E21-02-40	E21-03-40	.023
7.00	E21-02-50	E21-03-50	
10.00	E21-02-60	E21-03-60	

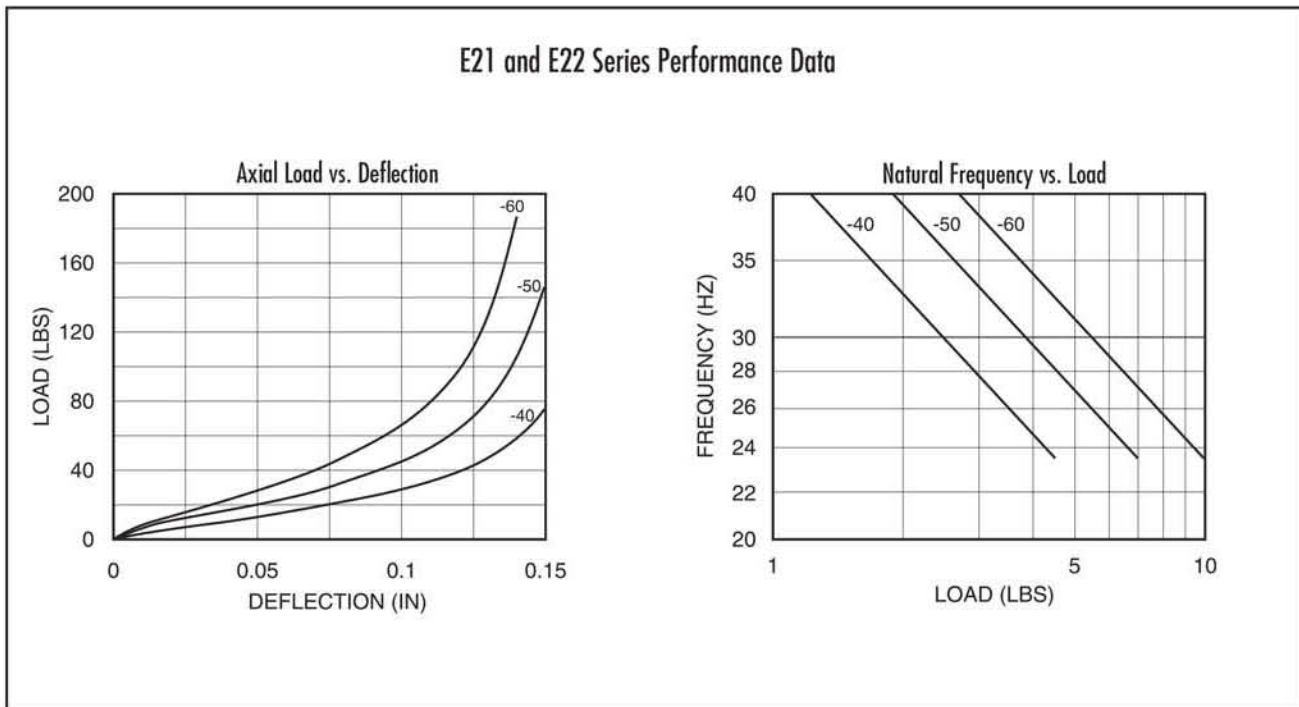

E MOUNT SERIES: E22

Dimensions & Performance Characteristics

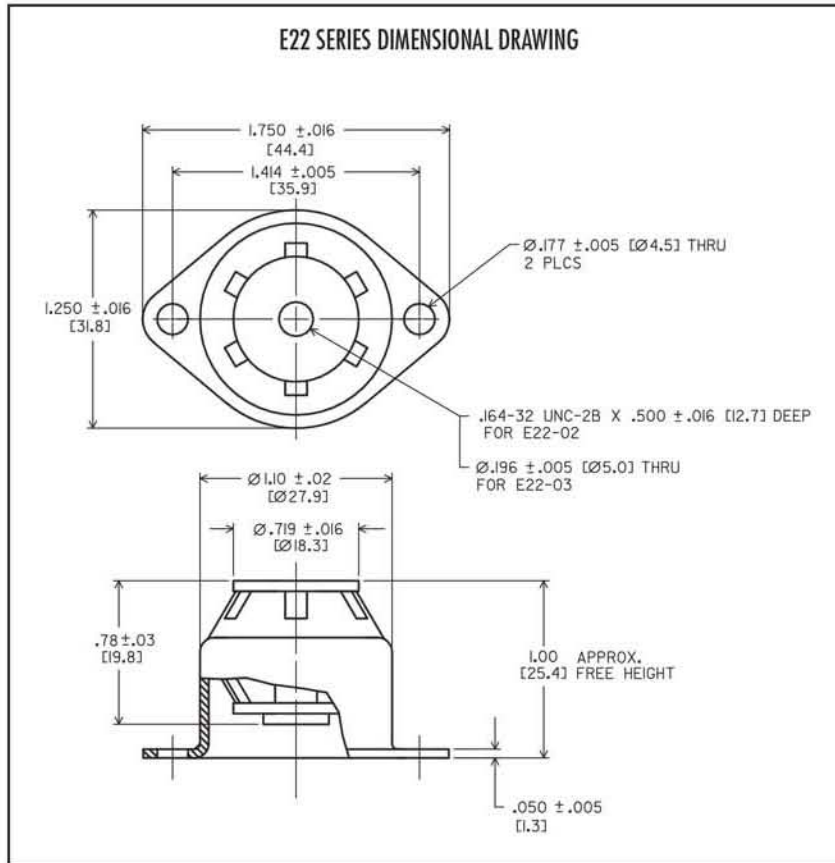

LOAD RATINGS			
Max. Load/Mount (lbs.)	Cup Type Tapped Core	Cup Type Thru Core	Weight (lbs.)
4.50	E22-02-40	E22-03-40	.045
7.00	E22-02-50	E22-03-50	
10.00	E22-02-60	E22-03-60	

